



Performance characteristics

- ◆ Suitable for viscous, non-viscous liquid transport
- ◆ Compact structure
- ◆ Exquisite appearance, color can be customized
- ◆ Plastic gear transmission, cost-effective

KHS series peristaltic pump introduction

Motor Selection - The KHS series of peristaltic pumps are two types of peristaltic pumps driven by a current-flow, 24V/12V DC motor that offer different voltage options.

Pump tube selection - Imported Norprene (N) and silicone tube (S) with a wall thickness of 1.6 mm for pump tubing, suitable for different transfer fluid requirements, and optional pump tubing size to meet different flow requirements.

The installation method is the way of fixing the plate and installing the L plate (see the attached drawing for details).

Transmission mode transmission is planetary gear transmission, reduction ratio 1:8

The main material - the upper cover is made of PC plastic, the pump body PA and gear are synthetic engineering plastics.

Performance parameter table

Code		S16	S40	N16	N40
ID*OD(mm)		3.2*6.4	4*7.2	3.2*6.4	4*7.2
Pump tube material		S	S	Norprene	Norprene
Flow rate (ml/min)	24V Brushed motor (SV) Current 0.4A	3 Rotor 210	320	200	310
	12V Brushed motor (SW) Current 0.8A	3 Rotor 210	310	200	300
Working conditions: Ambient temperature: 0°C-40°C Relative humidity: <80%					

Note: the above test data of KXF is measured at 20 °C at room temperature pure water under no pressure until the pump tube crack. Actual service life is related with medium, condition, temperature, humidity, voltage, speed and other factors, the measured data as a reference

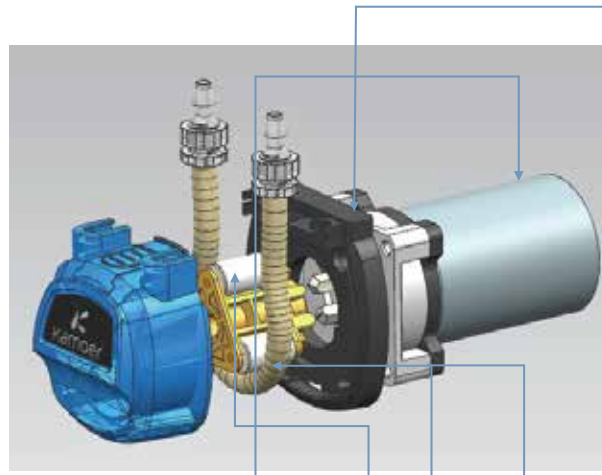

KHS- SV 3 N 16

Motor selection Rotor Pump tube material Pump tube size Installation method

Appearance size chart
Board mounting method

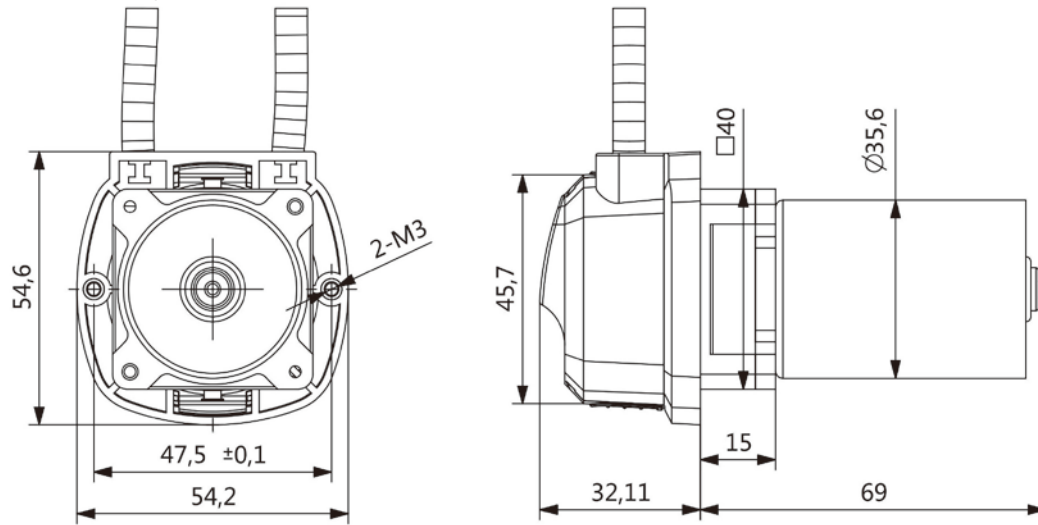

L board installation method

