

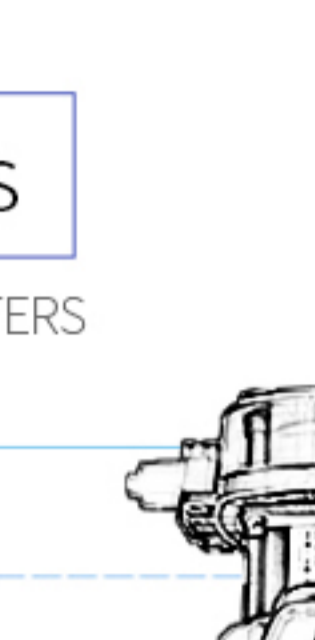

Reject mediocrity

Stepper motor large flow peristaltic pump

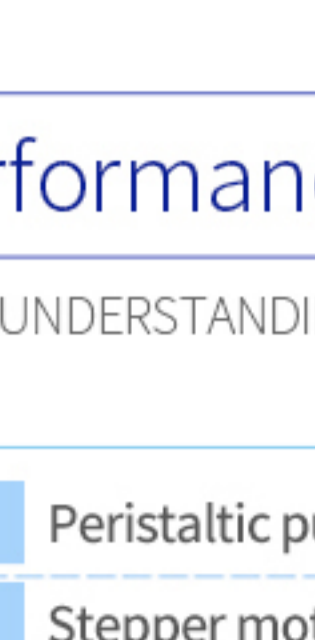
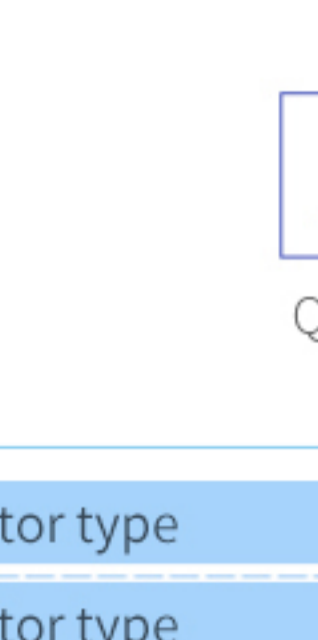

Performance parameters

QUICK UNDERSTANDING OF PRODUCT PARAMETERS

Motor type	Peristaltic pump
Motor type	Stepper motor
Model	KHL-SZ-S24/ KHL-SZ-S35/ KHL-SZ-B18
Flow	≥1300ml/min; ≥1800ml/min; ≥1800ml/min
Rated voltage	12V/ 24V
Load current	1.8A
Maximum power	≤45W
Pump tube size	6.4*11.4mm 7.9*12.7mm/ 7.9*11.1mm
Current flow speed	350rpm
Accuracy	Different flow error within 5%, single accuracy within 2%.
Suction	>2 meters
Head	>2 meters
Pump tube material	Low adsorption, good temperature resistance, and aging.
Pump tube life	≥500H
Noise	70dB
Product Weight	1320g
Drive models	4460.4, KMD-42, 2802, etc.
Ambient temperature	0 to 40 °C
Use ambient humidity	0 to 80% RH
Product life	>6000H
Motor parameters	Step angle 1.8°, two-phase four-wire, current 1.8A, wiring length 400mm, Terminal type HXT XHP-4 (pin 2.54 pitch)

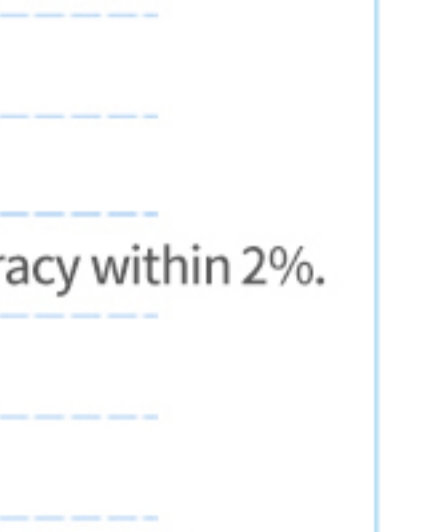

Powerful features Widely used

WIDE APPLICATION OF POWERFUL FUNCTIONS



Experiment



Filling and dispensing



Laboratory research institute

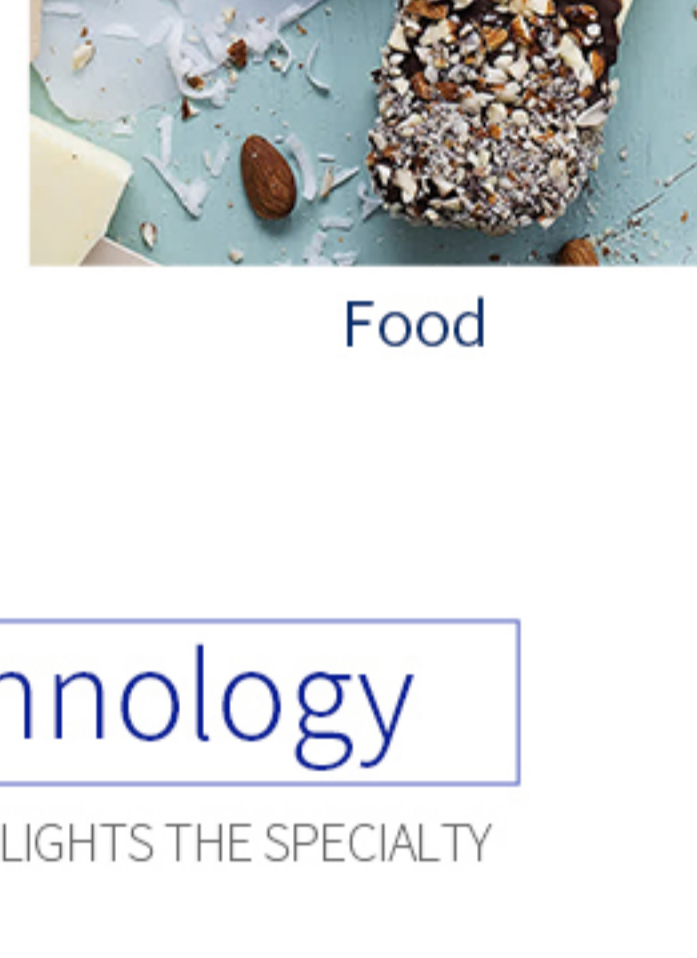

Food

Core technology

LEADING ADVANTAGE HIGHLIGHTS THE SPECIALTY



Dimensions at a glance

THE SHAPE AND SIZE ARE CLEAR AT A GLANCE

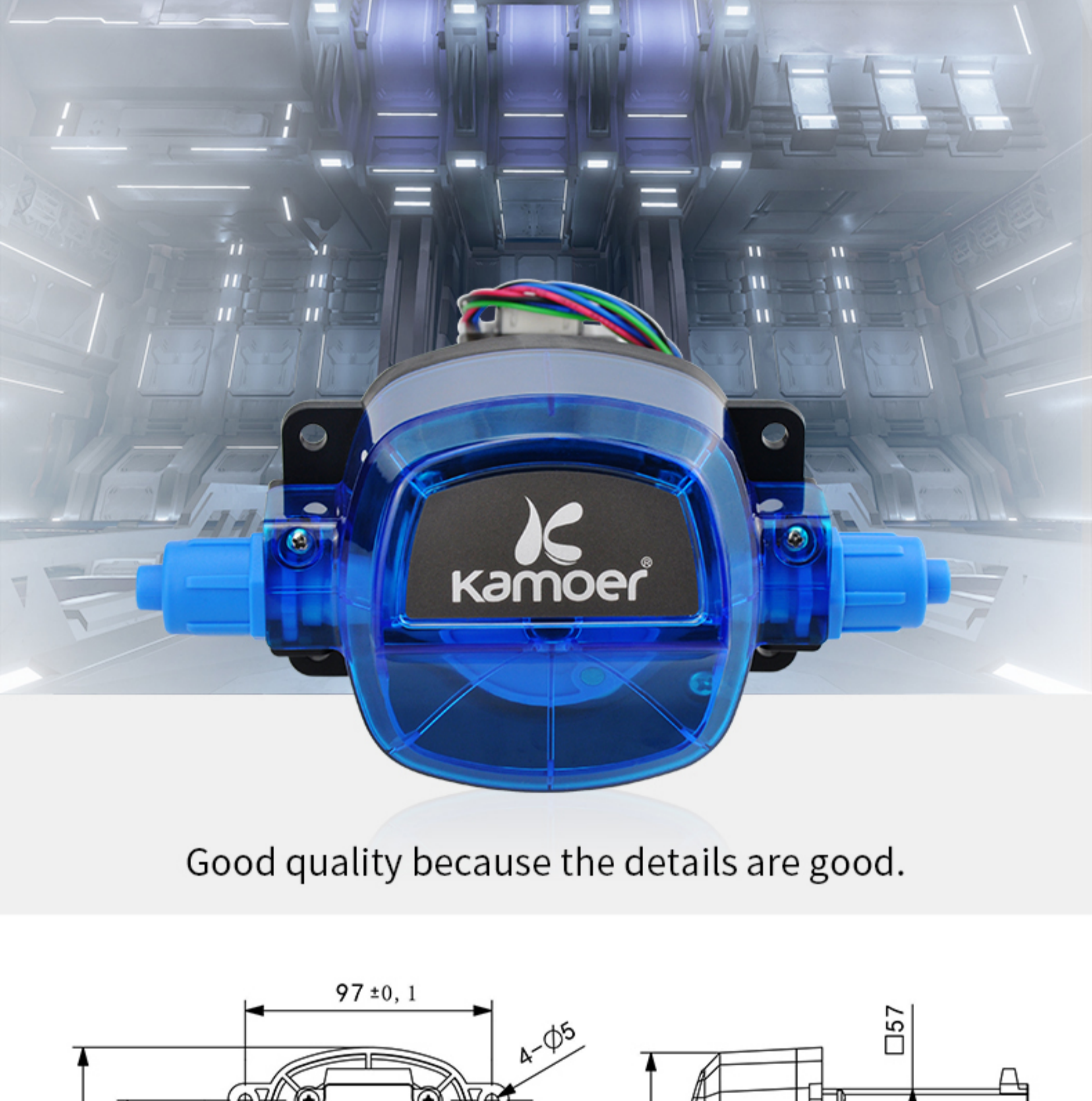

Good quality because the details are good.

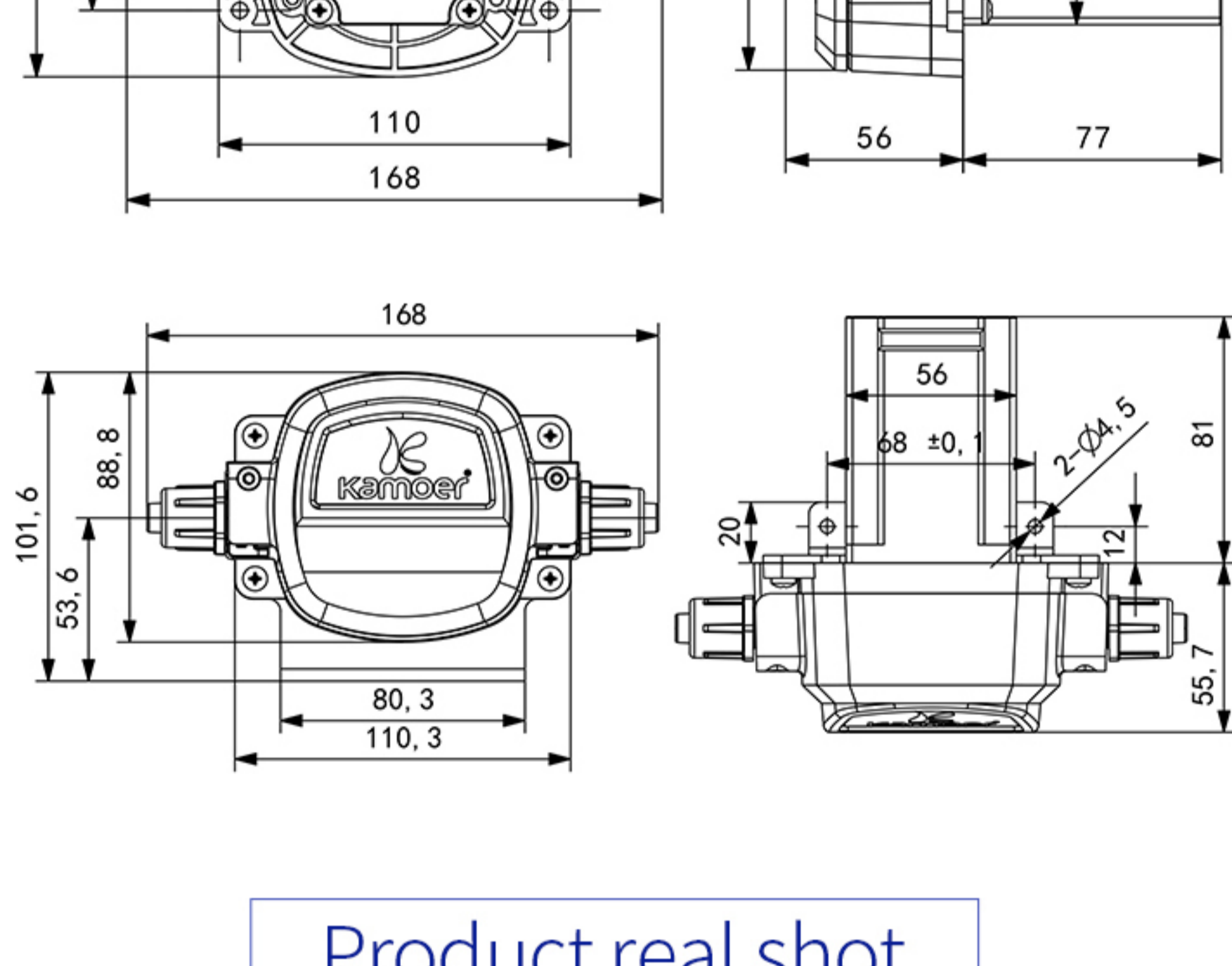

Product real shot

PRODUCT FEATURES AND INTRODUCTION



01 Performance

Suitable for viscous, non-viscous liquids transmission, large flow

02 Good appearance

Compact structure, the appearance of fine high-end



03 Multiple pump tubes

Available in a variety of pump tube sizes Food grade silicone tube, safe and secure



04 Stepper motor

57 stepper motor, a variety of drive options high precision, easy maintenance, fast response

